

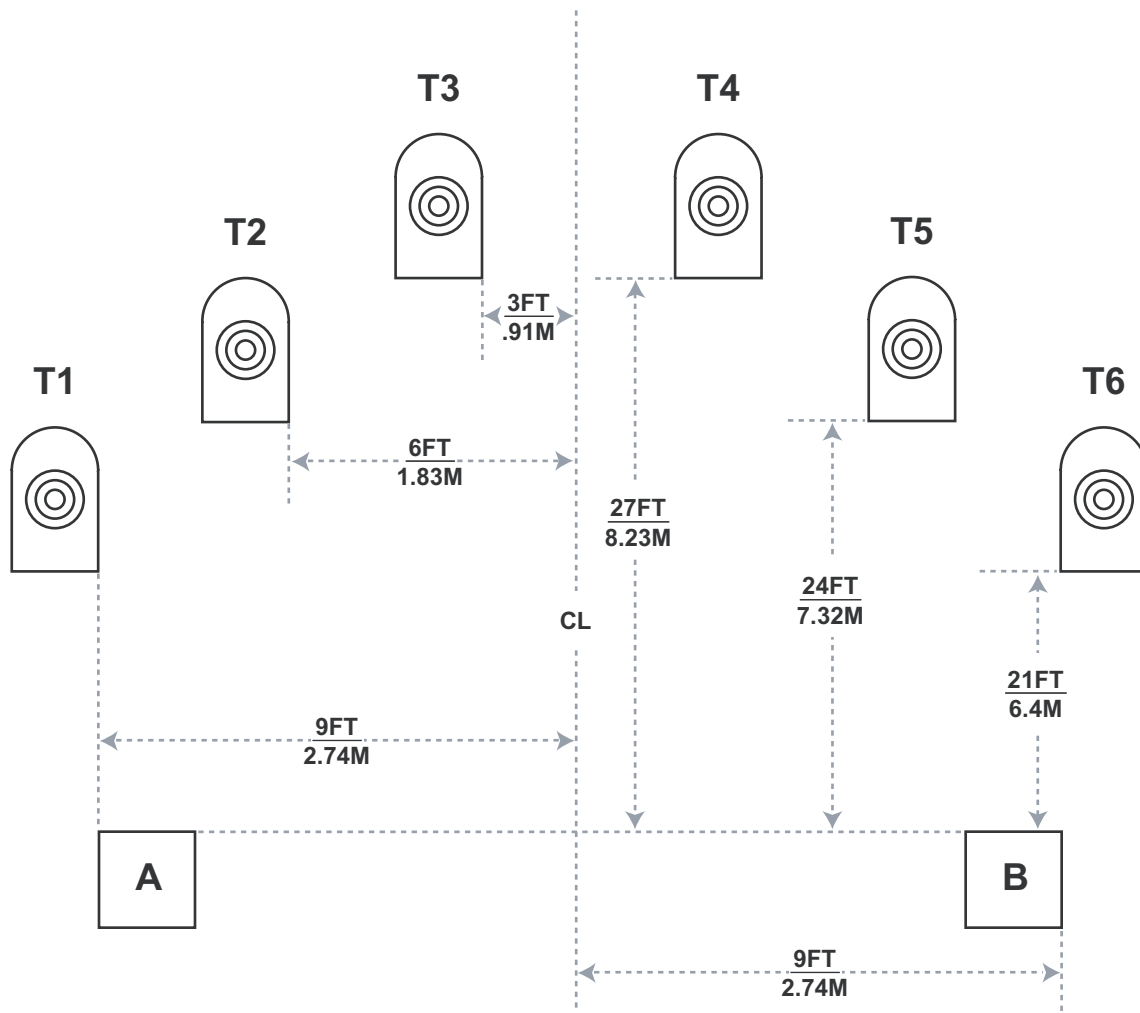

Times Two

CS-004
Modified by
Paul A. Wetzel
from USPSA
87-11



Drawing is Not to Scale!

Start Position: Standing in Box A or Box B, facing downrange, hands relaxed at sides.

Procedure:

At start signal engage appropriate targets, then move to other box and engage appropriate targets. From Box A engage only T1 thru T3 with only two (2) rounds each in any order. From Box B engage only T4 thru T6 with only two (2) rounds each in any order.

Scoring: Shots Limited

Targets: 6 NRA D-1 paper

Rounds: 12 maximum

Start: Audible

Stop: Last shot

Penalties: Per the ICORE rulebook. Foot faults, extra shots, extra hits, procedurals and misses +5 seconds per occurrence.

Stage Setup: Place targets per drawing dimensions. Set targets T1 thru T6 at standard height with top of target 1.65 m (5 feet 6 inch) +/- 5cm (2 inches) from ground. Alignment is shown to centerlines of boxes and targets, unless otherwise noted.

Shooting boxes are approximately 1m x 1m (3 feet x 3 feet).

CS-004

Shots Limited

Times Two



Target	A	B	C	M	Hits
T1					2
T2					2
T3					2
T4					2
T5					2
T6					2

R.O. _____

Shooter _____

Total Hits					12
------------	--	--	--	--	----

Time Factor	x0	x1	x2	x5
		+		+
		Extra Shots		
		Extra Hits		
Notes		Procedurals		

	Clock Time
	Hit Time Added
X5=	+ Extra Shots
X5=	+ Extra Hits
X5=	+ Procedurals
	Total

Name _____

ICORE Number _____

Date _____ Club _____

Classic / Limited / Open (Circle one)